

Kelvion

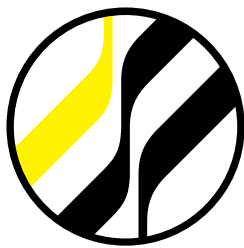
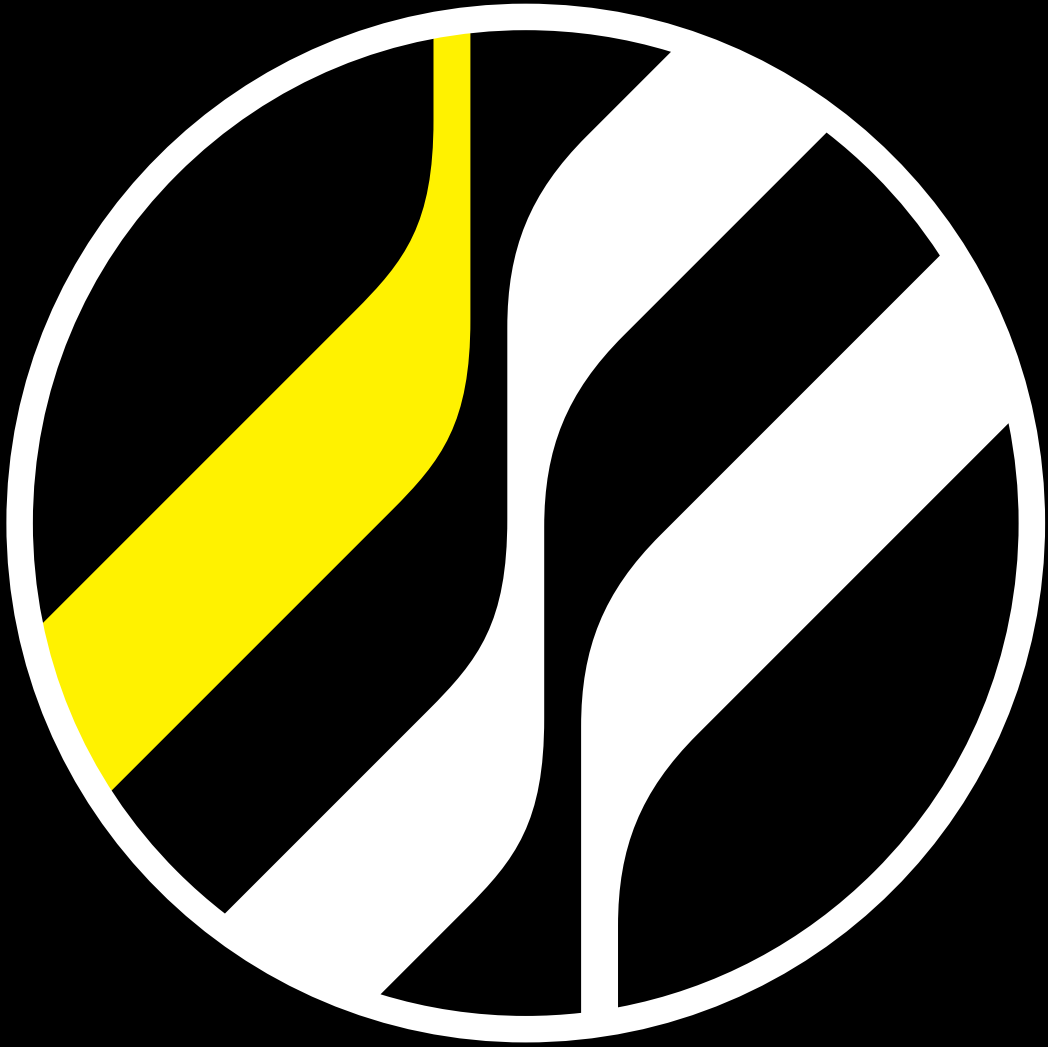

Plate Heat Exchangers

TAILOR-MADE PLATE HEAT EXCHANGER SOLUTIONS





WE ARE KELVION – THE NEW BRAND IN HEAT EXCHANGE

GEA Heat Exchangers has changed: another new standalone company has been created out of the former Heat Exchanger Division of the GEA Group AG. The name Kelvion is new, but we continue as global experts in heat exchange. As always, we remain committed to earning your trust.

You'll still recognize us. We continue to develop our products, manufacture them with precision and distribute globally. We continue to offer one of the world's largest heat exchanger product portfolios: Plate heat exchangers, shell & tube heat exchangers, finned tube heat exchangers, modular cooling towers and refrigeration heat exchangers for a wide range of applications.

We operate in global markets for power generation, oil and gas, chemistry, marine applications, climate and environment, and food and beverages. From us, you can expect products with outstanding levels of efficiency, safety, and sustainability. More importantly, we care about your business, like close, trusted partners.

Customers rely on us to understand their needs, boost their performance, and deliver products that always get the job done. We compete for the toughest deals, in the harshest environments. But we're not too big to care. We're Kelvion – ready to take on the challenges of heat exchange. www.kelvion.com

Experts in Heat Exchange.

TAILOR-MADE SOLUTIONS IN AREA OF APPLICATION AT HO

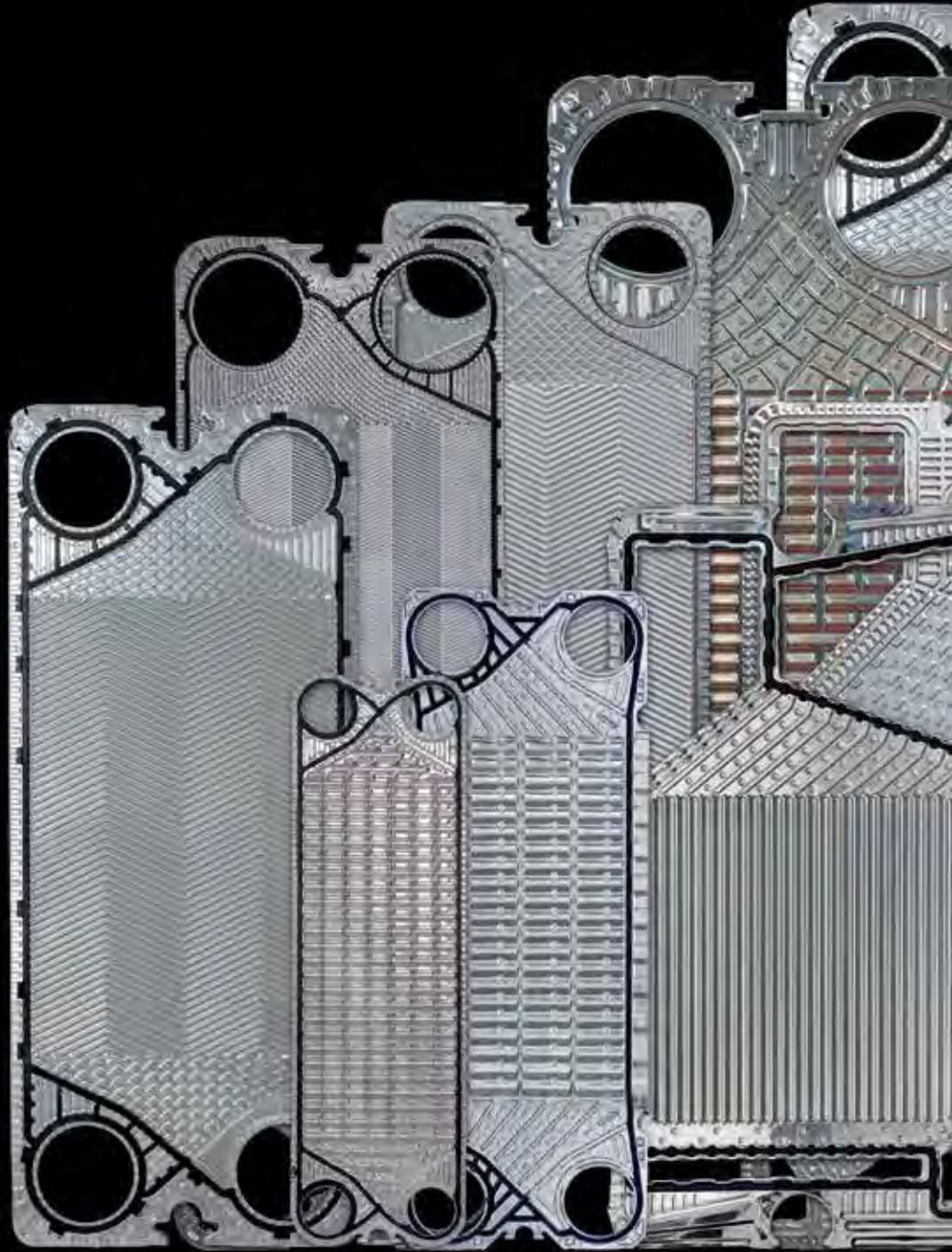

As the worldwide technology leader in the manufacture and development of plate heat exchangers, we have one of the most extensive product ranges on the market. Our product diversity ranges from gasketed to brazed and even fully-weld-

ed plate heat exchangers. This includes process-optimised model ranges that are unique in their number and special functions. This makes us absolute specialists when it comes to developing tailor-made solutions for your applications.

I EVERY OME

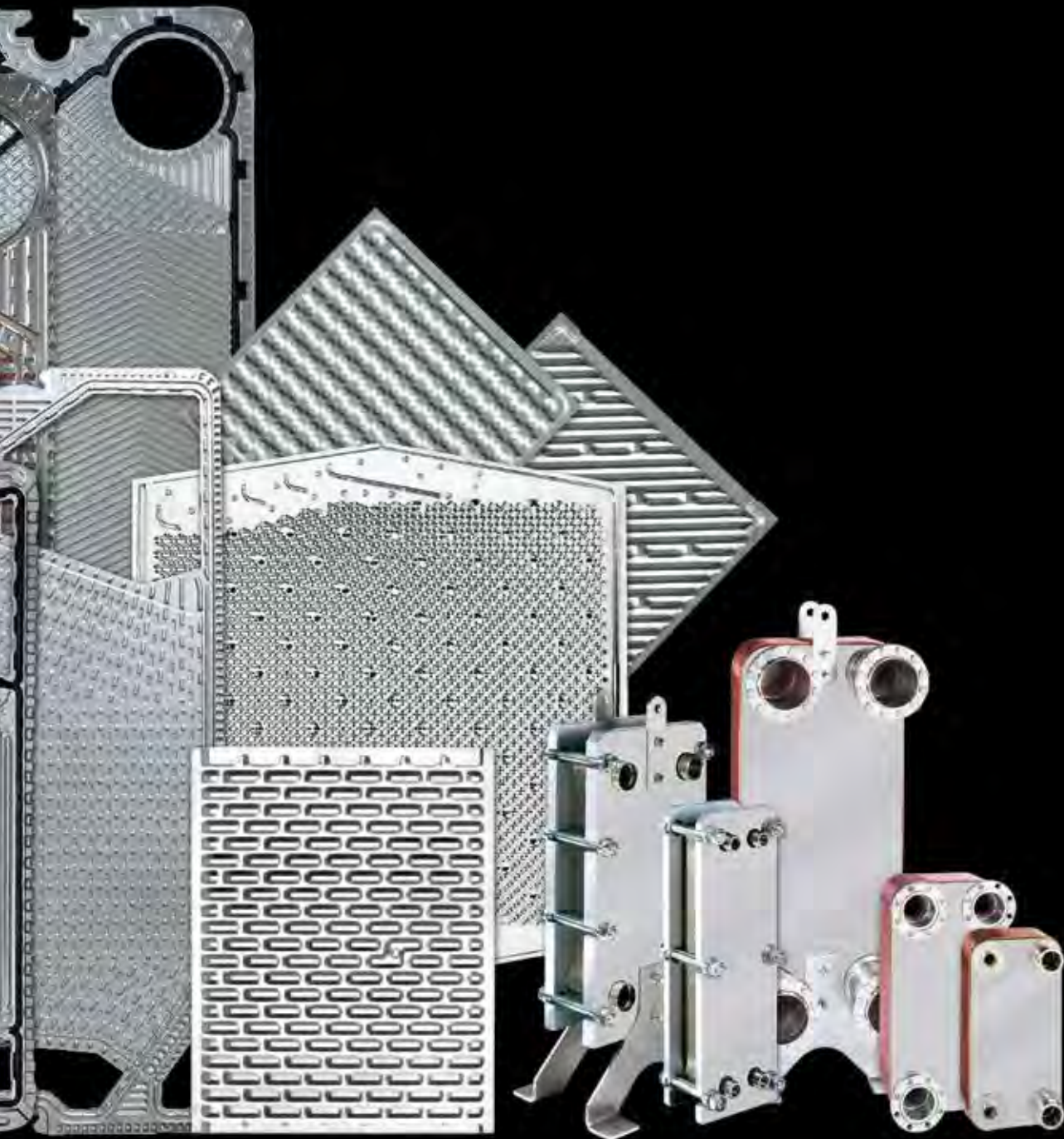

All Kelvion enterprises make an above-average investment in research and development. The organisation and coordination of knowledge transfer plays a leading role in this process. Core competency is thus secured and further

extended. This is to your direct benefit. It is only possible to continuously develop efficient plate types for new fields of application with the aid of extensive research and development work.

GASKETED PLATE HEAT EXCHANGERS

THE BENCHMARK OF EFFICIENCY

The gasketed plate heat exchangers reveal what passion, scientific curiosity and technological expertise can achieve. The facts: high efficiency at low operating costs, greater application possibilities at a lower investment costs. Continuous further development of the plate series targeted at the requirement of the thermo- and hydrodynamic industries

also ensure that you can achieve maximum economic efficiency. The range of plate corrugations and plate lengths enables them to be made to measure to your requirements. In addition, maintenance-friendly assembly and sealing technologies are applied, which assure the flawless seating of the gasket and plate package.

A suitable plate heat exchanger series for each production stage:

	NT Series	NH Series	ND Series	NX Series	NL Series	LWC Series	Free Flow NW Series	Conci-therm	GG Series
Foodstuff industry Our PHEs heat and cool so that in the end it tastes good for everyone.	X		X	X	X	X	X	X	
Sugar industry In the case of sugar cane and beet processing, we ensure that nothing is burned and that primary energy consumption is minimised.	X					X	X	X	
Chemical industry Undertake entire job in critical areas and offer individual solutions for high levels of safety and minimal energy consumption.	X	X	X	X		X	X		
Renewable energy We contribute to the replacement of fossil fuels by sustainable fuels.	X	X			X	X	X		
HVAC (Heating, Ventilation, Air-conditioning, Cooling) We have the technical diversity required for remote heating, refrigeration, air-conditioning, solar, pool and surface technologies.	X	X	X	X		X			X
Energy generation Our PWTs are used for turbine cooling in power stations as well as in the field of power-heat cogeneration.	X	X	X	X					
Heavy industry Whether for steel production, mechanical engineering or in the automotive industry - there is a plate heat exchanger that matches every field of application.	X	X	X	X					
Marine For the cooling of ship propulsion systems and generators and for the air-conditioning of interior spaces.	X	X	X	X		X			
Paper industry We put forward a persuasive case in the energy-intensive pulp and paper production sector with high levels of heat transfer and energy-saving processes.	X						X		
Oil/Gas Gaseous, fluid and dual-phase media are controlled safely by our PHEs, even under extreme conditions.	X	X		X		X			
Refrigeration industry Always stay cool. No matter what must remain refrigerated, we ensure that it takes place as required and cost-effectively.	X					X			

The N Series

QUALITY AND FLEXIBILITY AT ITS BEST

You can benefit from the innovative technology of our gasketed plate heat exchangers no matter whether high pressure or harsh operating conditions. For tall buildings or for low investment, operating and service costs. For use with critical media or for high-performance remote refrigeration systems.

Thanks to the technical characteristics and the ability to swap various plate series in the same frames, the N Series offers an extraordinarily broad spectrum of applications – in the broadest range of sectors and for the most diverse media.

N for high flexibility

Even if the medium or requirement changes. There is no greater flexibility: Nearly all of the N series can be used in the same frame and various plate numbers.

EcoLoc gasket system

Done in a matter of moments: Thanks to their glueless EcoLoc gaskets, they can be exchanged quickly and simply.

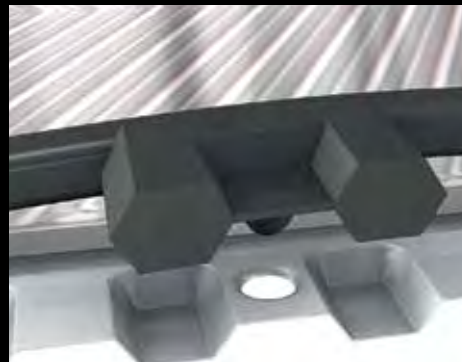
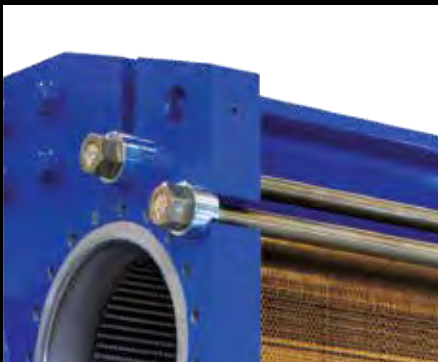

OptiWave design

Optimised corrugation leads to the highest heat transfer rates by means of the uniform distribution of media over the entire width of the plate.

PosLoc -assembly

The PosLoc assembly system leads to a stable, perfectly aligned plate package. The gaskets lie exactly alongside each other and remain functional for longer.

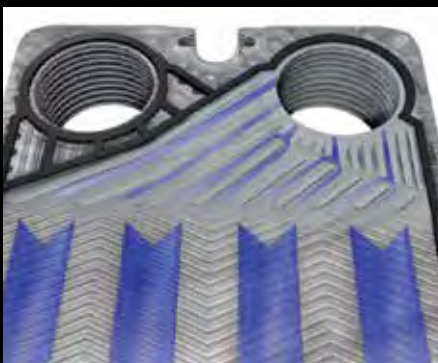

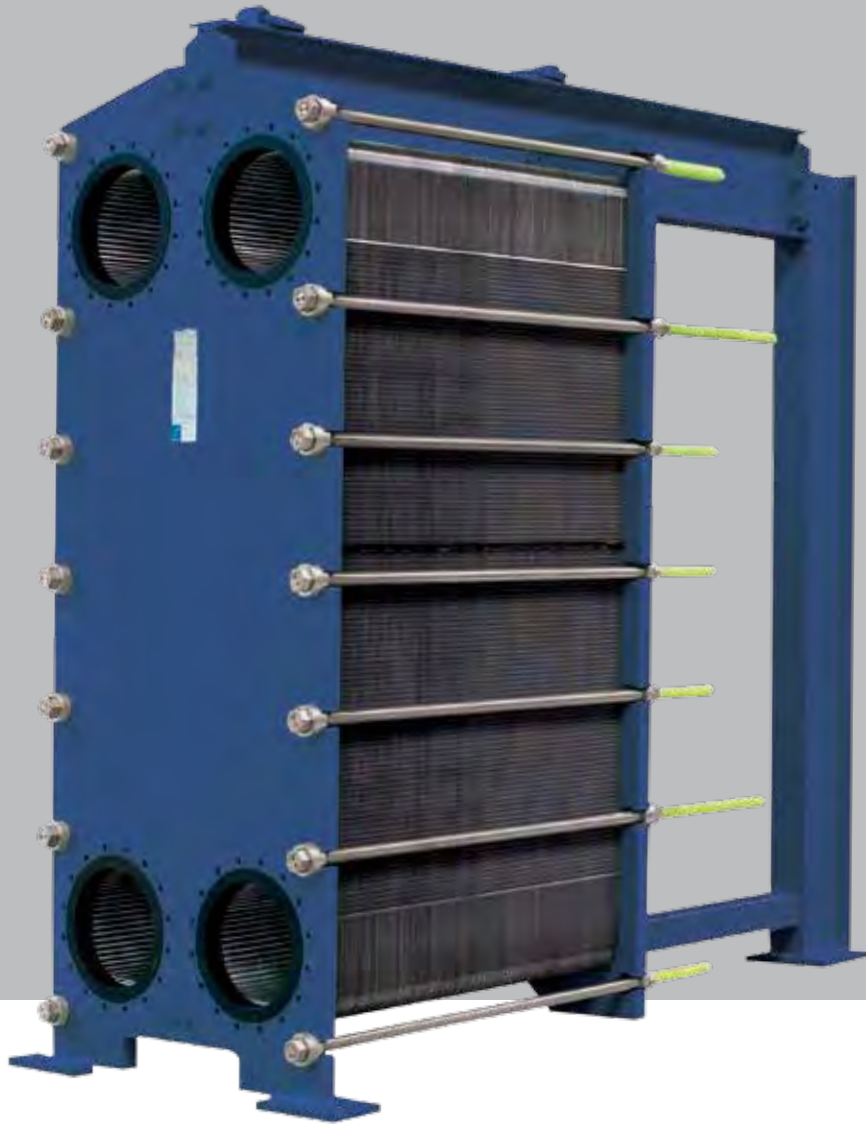

NT Series

LEADING TECHNOLOGY FOR ALL APPLICATIONS

The NT Series offers pure application diversity. Thanks to plate types in numerous lengths as well as profile variants, the NT Series is suitable for every requirement. They are decisive in terms of greater performance, more options and less investment. Thanks to the optimised plate design of the NT

Series, you can achieve your targets with fewer heat exchanging surfaces, thus saving investment costs. In combination with a flexible and universal plate range, the NT Series can now be tailor-made to your purposes and their field of application more precisely and with greater flexibility.

Their advantages at a glance

- flexible solutions for special requirements
- OptiWave design – for optimal media distribution
- PosLoc assembly – for a stable plate package
- EcoLoc gasket system – for secure seating of the gaskets



NH Series

HIGH PERFORMANCE UNDER HIGH PRESSURE

Wherever high pressure resistance is required by the applications, the newly-developed NH Series proves its extreme load capacity. You also benefit from the greater surface area in terms of high efficiency heat exchange. This is enabled by the combination of special materials and the innovative design, which offers a different corrugation filed when compared to the NT Series. This has significant effects: The high-performance plate heat exchanger withstands operating

pressures of up to 30 bar. Apart from this, the shaping of plate materials such as titanium or special materials such as SMO 254, Alloy 59, Alloy 686 and C-276 is naturally possible. With a plate design that has been adapted to the requirements of oil and gas production, the NH Series provides you with heat exchangers that can best handle pressure.

Their advantages at a glance

- increased pressure resistance thanks to a new plate design
- PosLoc assembly – for a stable plate package
- OptiWave design – for optimal media distribution
- EcoLoc gasket system – for secure seating of the gaskets

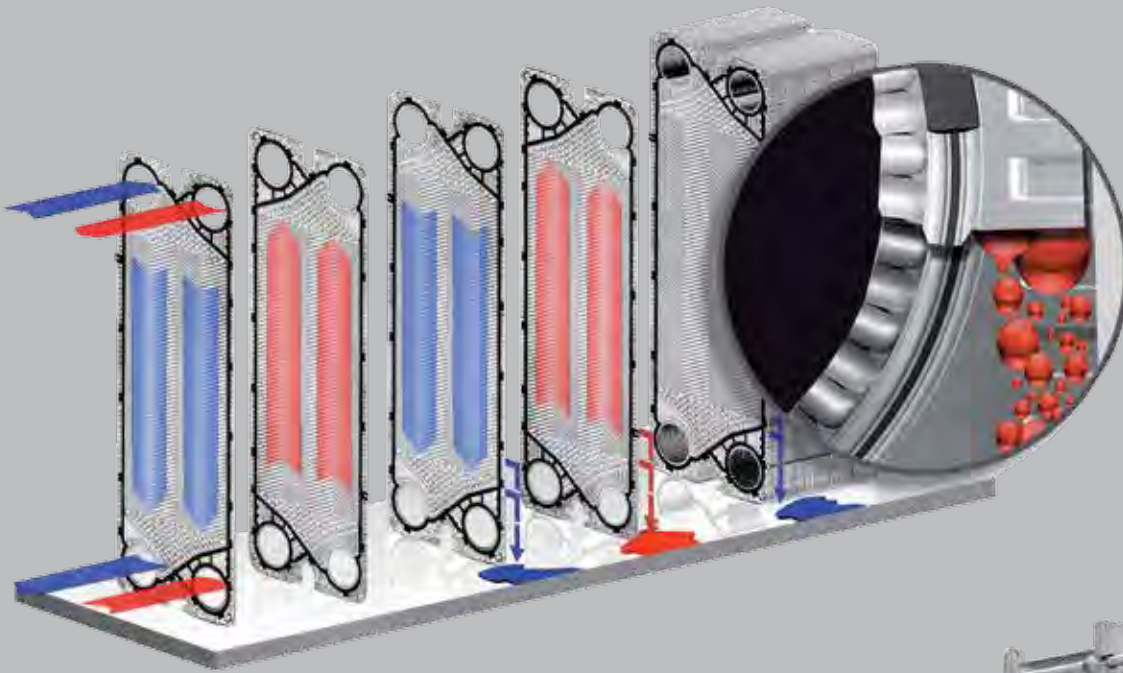

ND Series

PLATE DUO PLAYS IT COMPLETELY SAFE

With the ND Series, our experts have conceptualised an extremely reliable variant of the conventional gasketed heat exchanger. Two especially thin plates, the core openings of which are welded, create a narrow leakage gap within a double wall. In the event of the rupture of a plate, this clever solution ensures that the possibility of incompatible media remains excluded and that the rupture is indicated.

The compact design and the functionality of the Safetytherm meets the high standard that is expected of an industry leader such as Kelvion. Our customers can rest assured. The ND Series shines as an effective and low-maintenance double-wall solution, which in the same way as the famous double-bottomed grid assures a high level of production reliability.

Their advantages at a glance

- high production security with low risk of leakage
- OptiWave design – for optimal media distribution
- EcoLoc gasket system – for secure seating of the gaskets
- PosLoc assembly – for a stable plate package

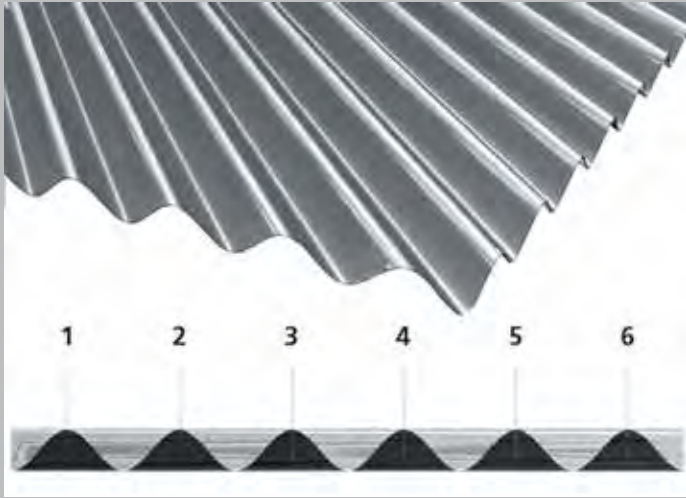

NT Series corrugation

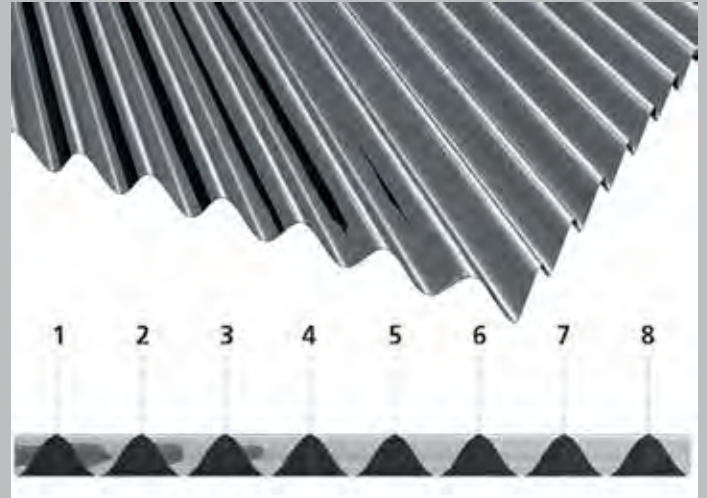

Narrow NX Series corrugation. The narrow corrugation makes the NX pressure resistant and ensures a highly turbulent flow behaviour.



NX Series

HIGH PERFORMANCE FOR EFFICIENT REMOTE REFRIGERATION

Our NX plate heat exchangers are based on the successful NT technology. They have been specially developed for high-performance remote refrigeration systems, which require minimal temperature differences and maximum pressure resistance. The NX Series can show their strengths especially in ex-

treme climate zones and in tall buildings as a means of system separation for different operating pressures. Pressure resistance runs up to 30 bar. That corresponds to a water column 300 meters high. The temperature fluctuation lies at a maximum of 1°C and is thus adequate for the most demanding tasks.

Their advantages at a glance

- highest heat transfer rates
- extremely small temperature differences
- OptiWave design – for optimal media distribution
- PosLoc assembly – for a stable plate package
- EcoLoc gasket system – for secure seating of the gaskets

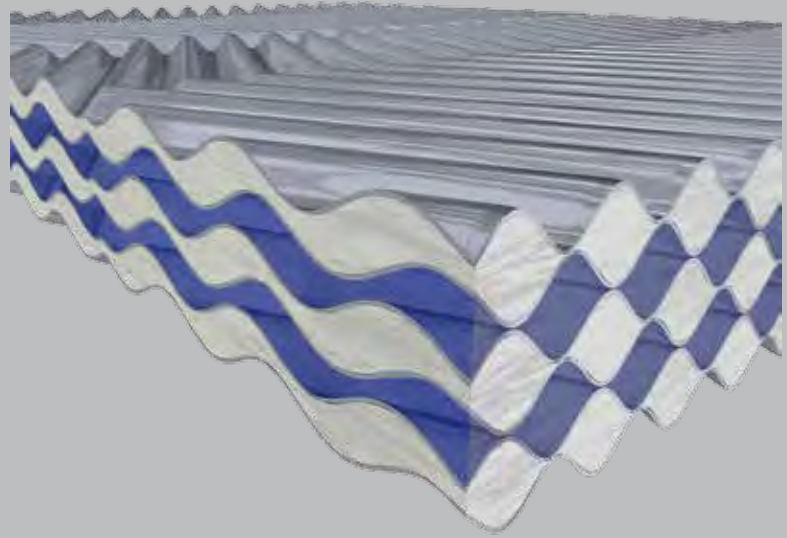

NL Series

FOR HIGH VISCOSITY AND THE MOST STRINGENT DEMANDS

The new NL Series has been specially developed for fluids with high viscosity as well as for viscous and shear-sensitive media. This not only offers all the advantages of the NT family, such as PosLoc, EcoLoc and the proven OptiWave design but also a clearly deeper corrugation depth. The result is a particularly gentle and uniform heat treatment of sensitive products such as dairy products, foodstuffs and beverages.

Due to the outstanding interaction of the plate profile and the corrugation depth, the flow properties are improved and blockages are reduced to a minimum. Thanks to the gaskets with foodstuff approval, the NL Series is best suited to applications in the sugar and foodstuff industries. In addition, the field of application ranges from the chemical and paper industries through heavy industry to the oil and gas industry.

Their advantages at a glance

- Extended service life due to greater corrugation depth, which improves the flow and reduces the tendency to clog up.
- Pressure resistance runs up to 25 bar
- Ideal for fluids with higher viscosity as well as for viscous and shear-sensitive media.
- Suitable for media that contain short fibres or small particles/solids
- Gentle product handling

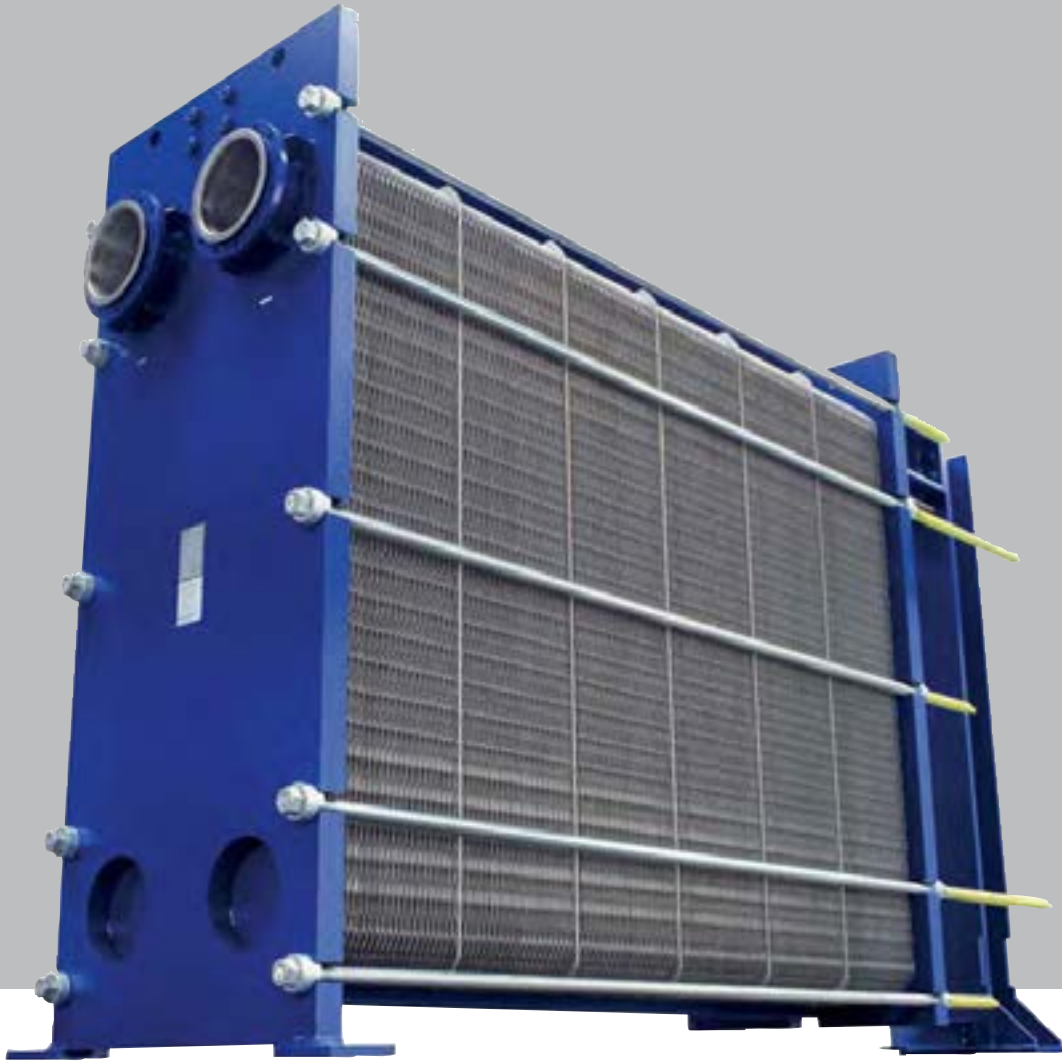

NW Series

FREE FLOW EVEN WHEN IT'S THICK

With the NW Series we have conceptualised a heat exchanger plate that has been specially developed for use with media containing particles and solids. These solids tend to clog plate heat exchangers, thus causing costly downtime, such as can occur in bio-ethanol production, in the pulp and paper industry and in waste-water treatment. The NW Series offers a solution to this problem, as thanks to the deeply corrugated plate gap, blockages are practically impossible.

The herringbone corrugation with metallic support points ensures the required highly turbulent flow that prevents fouling and contributes to the self-cleaning of the plates and in addition increases the heat transfer performance. Taken in combination, this leads to a longer service life of the plate heat exchanger and your maintenance costs are notably reduced.

Their advantages at a glance

- free flow for media containing particles
- longer service life, lower operating costs
- minimal pressure loss, even with viscous media
- turbulence promotes the self-cleaning effect
- high pressure resistance

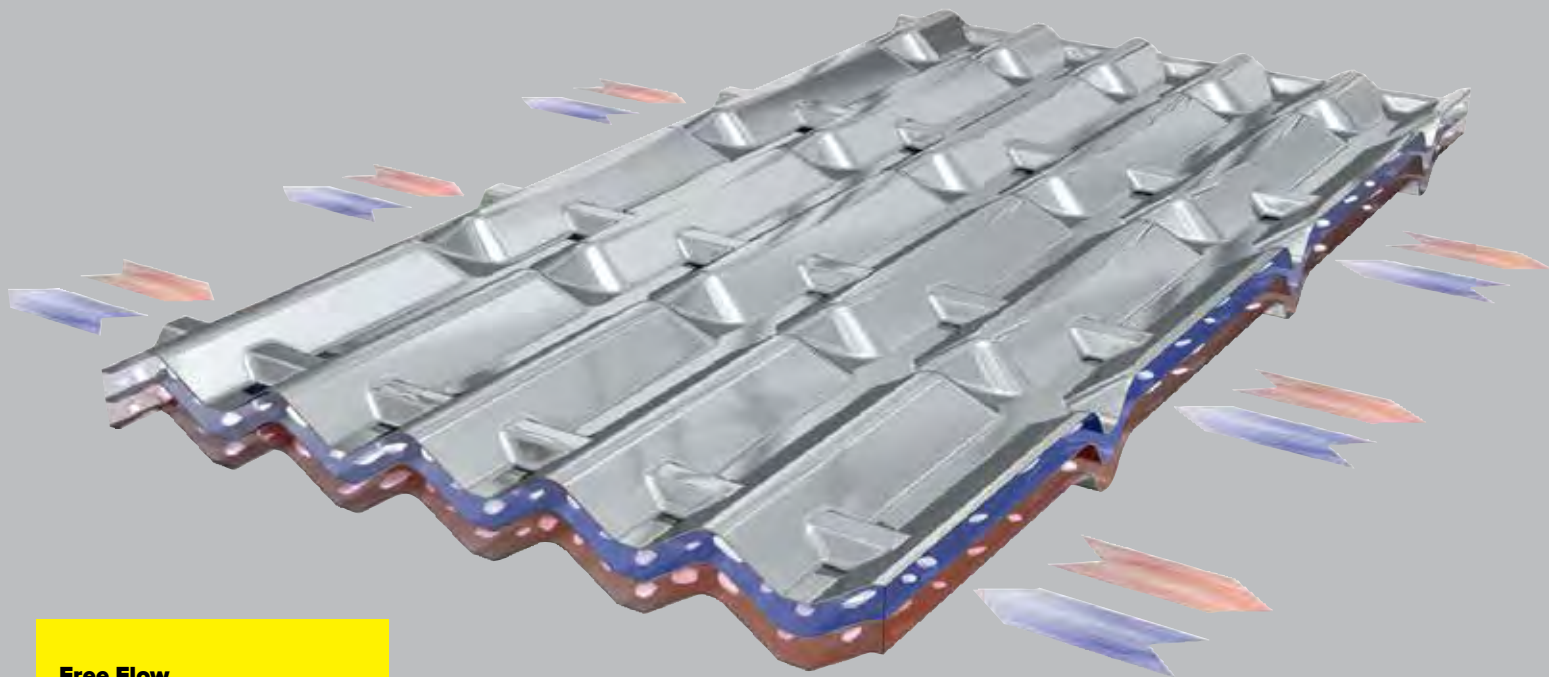

Free Flow

The constant-width gap ensures blockage-free operation.

Free Flow Series

FOR FIBRE- AND SOLID-BEARING MEDIA

Our Free Flow plate heat exchangers are ideally suited to media that contain fibres and solids. With their low investment and operating costs, they are the alternative to shell-and-tube and spiral heat exchangers. Predesigned for use with media containing fibres and solids, the Free Flow series is recommended for use in the sugar and paper industries. Their special feature is focused precisely on use with media containing fibre and

solids, which are beyond the capabilities of conventional plate exchangers. And this is precisely where the field of application of our Free Flow plate heat exchangers begins. Their special feature is the constant-width flow area between the individual plates as well as their coarsely fluted profile. The space between the plates measures up to 12 mm.

Their advantages at a glance

- blockage-free operation thanks to gap of constant width
- especially suitable for applications involving media containing fibres and solids
- the alternative to shell-and-tube and spiral heat exchangers thanks to smaller investment and operating costs as well as smaller space requirements

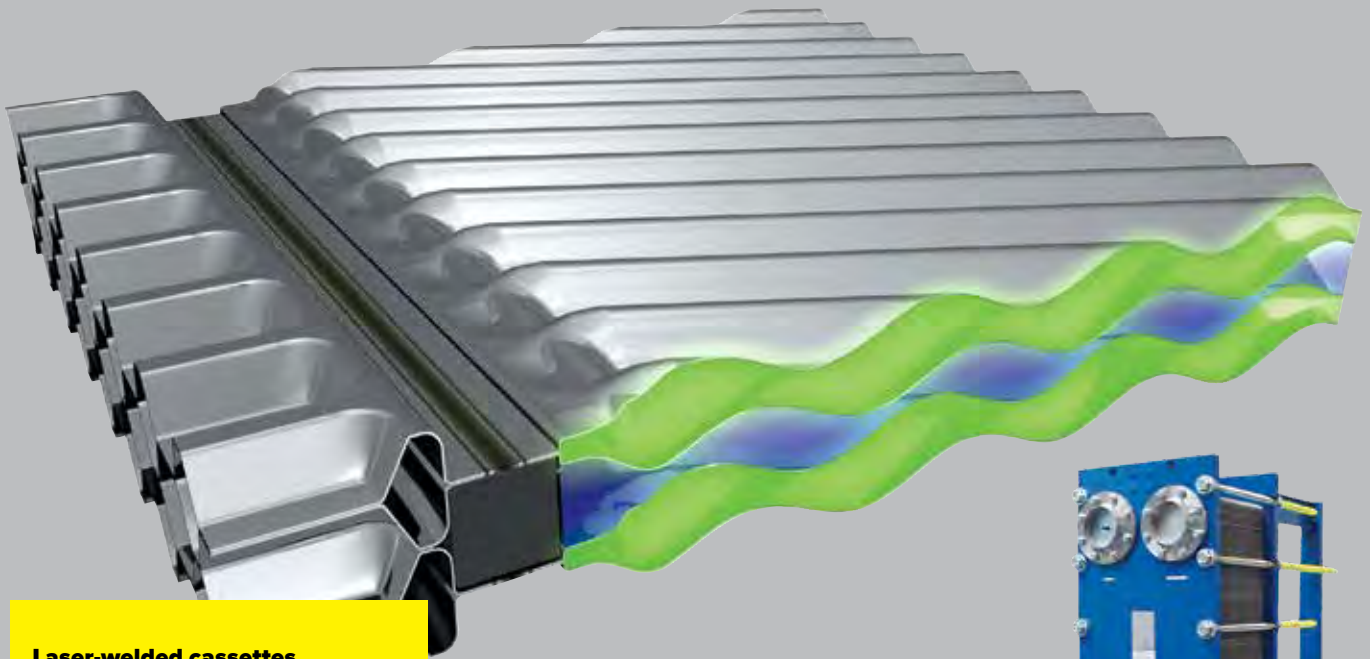

Laser-welded cassettes

The precisely manufactured laser weld seam hermetically seals the flow field.

LWC Series

NT PLATE TECHNOLOGY THAT IS ALSO FOR CRITICAL MEDIA

Conventionally sealed plate heat exchangers soon reach their limits when used with critical media. Kelvion solves this problem with the most modern technology. This is because aggressive media can also flow in the laser-welded cassettes of the LWC plate heat exchangers. Based on the NT plate technology, the LWC Series is manufactured according to the most up-to-date methods of cal-

culatation, design and manufacture. Our LWC plate heat exchangers function according to the principle of flow channels that are 100 % separate from each other. This absolute separation of channels is what makes many industrial applications at all feasible.

Their advantages at a glance

- easy assembly, cleaning access from the product-side
- PosLoc assembly – for a stable plate package
- laser-welded cassettes assure the highest process reliability even in the case of aggressive media
- EcoLoc gasket system – for secure seating of the gaskets
- OptiWave design – for optimal media distribution

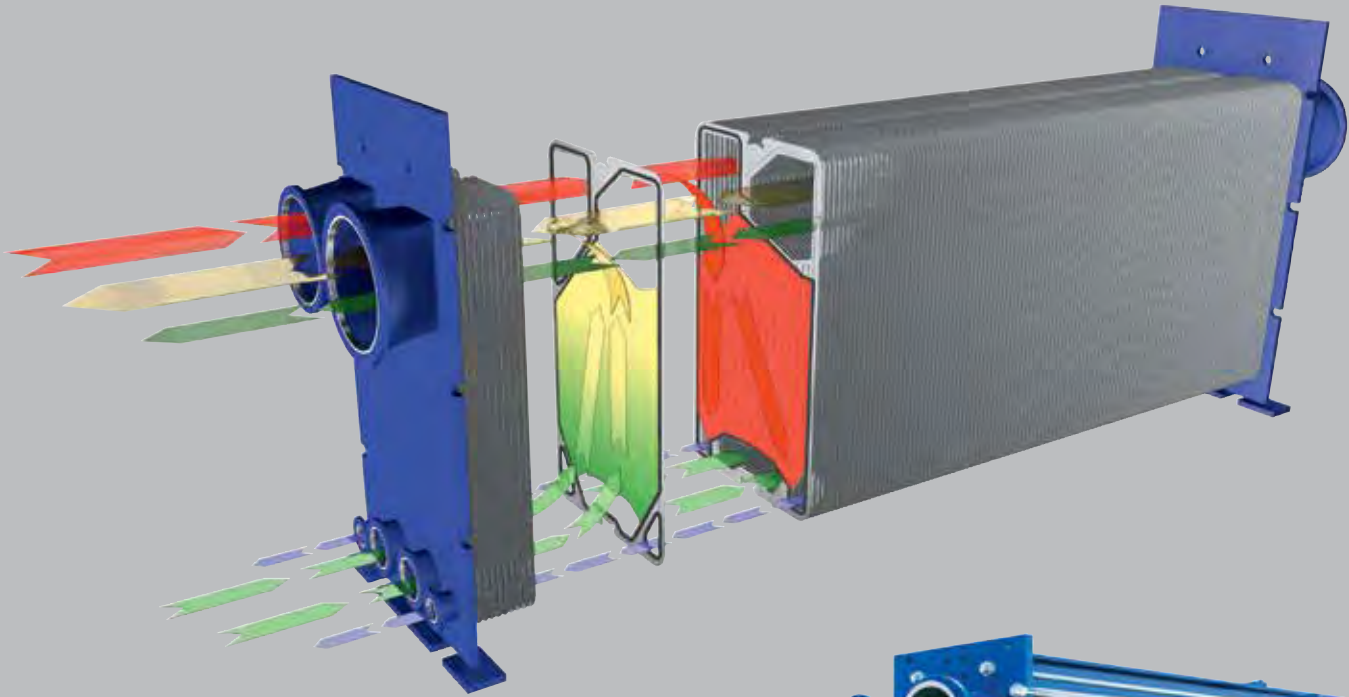

Treats your products gently
Minimal dwell times assure gentle handling of the product.

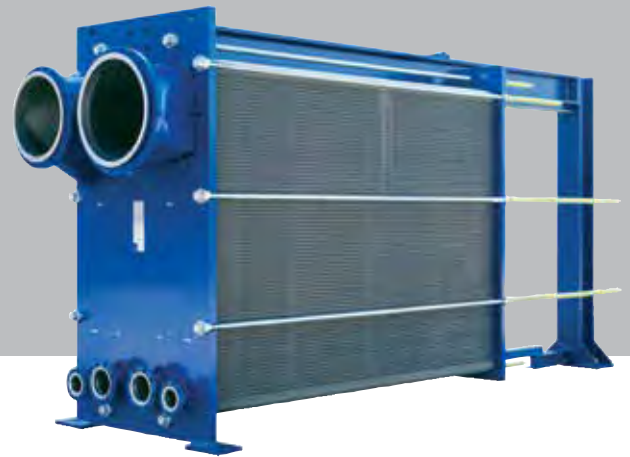

Concitherm

PLATE EVAPORATORS WITH HIGH PERFORMANCE

The Concitherm Series provides particularly high performance in rising-film plate evaporators that are often used in the sugar industry. In addition, they are suitable for use as boosters in combination with conventional tube-type evaporators. The optimised plate structure of the Concitherm Series makes it possible to have wide gaps with only a few contact

points over up to 3 m² of heat transfer area per cassette. At the same time they offer convincingly greater heat transfer compared to conventional shell-and-tube heat exchangers.

Their advantages at a glance

- 3 m² heat exchanger surfaces per laser-welded cassette enable high evaporator output and a compact design
- no clogging and easy cleaning reduce the production costs

A convincing solution

With its GG Series, Kelvion presents a convincing solution to the details of potable water-heating. They combine the many advantages of our gasketed and brazed plate heat exchangers.

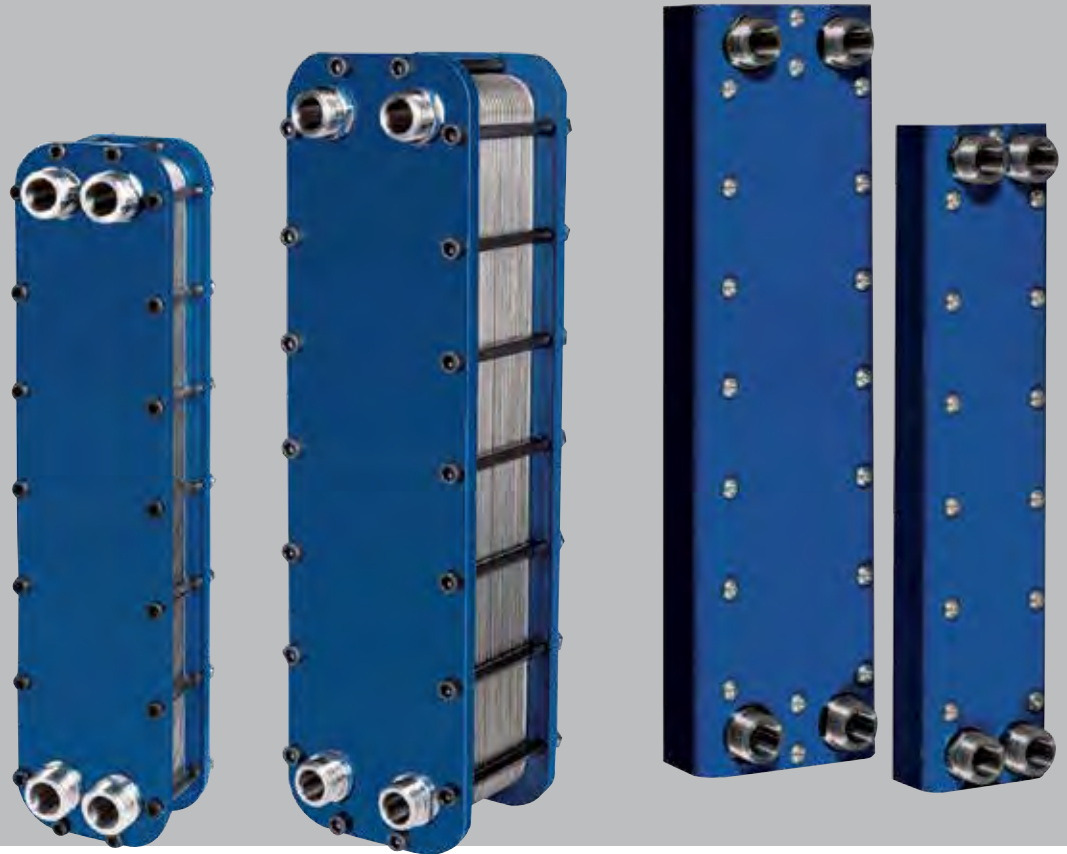

GG Series

GASKETED PLATE HEAT EXCHANGERS FOR HEALTHY DRINKING WATER

Anyone who requires potable water is dependent on extremely efficient and reliable plate heat exchangers for it to be heated. Our plate heat exchangers comply with European and international requirements and function with all the reliability that is to be expected from an industry leader such as Kelvion. We regard strict requirements and statutory regulations to be an incentive. With its GG Series, Kelvion presents a convincing solution to the special requirements of potable water-heating. In the search

for a plate heat exchanger that is free of non-ferrous metals, our experts have found a solution that is as affordable as it is clean. The GG Series combines the many advantages of our gasketed and brazed plate heat exchangers in an elegant manner. A special gasket, combined with stainless steel plates and a made-to-measure frame design form the basis of a cost-effective and food-safe heat exchanger.

Their advantages at a glance

- preferred for potable water applications
- corrosion-proof
- long service life
- FDA-listed gaskets
- smallest installation conditions

EcoBraz

COMPONENTS FOR HEATING SYSTEMS, HEAT PUMPS AND REFRIGERATION



A suitable plate heat exchanger series for each production stage:

	Description	Specifications
The GBS Series Copper brazed Strong performers – variable sizes Multiple applications	A brazed all-rounder that can be used for applications up to 31 bar and +200°C	Heating/service-water systems Under-floor heating Super cooler and condensers Economizer Refrigerant evaporator Oil coolers and many other industrial applications
The GBH Series Copper brazed Stay cool – even under high pressure	The GBH Series is designed for pressures up to 45 bar and is most suitable for applications with the environmentally-friendly R410A refrigerant	Evaporators in air-conditioners Heat pumps for heating and hot water production Process cooling Economizer Super cooler and condensers
The GBE/GKE Series Copper brazed The economical solution at full output	Our “E” stands for Eta: greatest efficiency at lowest costs These efficient plate heat exchangers give you total control: Size, weight, output, quality and economy	Modular design Compact and cost-effective ConBraz design availability Heating and service water systems Hydraulic applications
The GWH Series Copper brazed High pressure heat exchanger of the 2nd generation	The GWH Series – the solution for applications with high mechanical and thermal loads Robust, compact heat exchanger for industrial applications with an operating pressure of up to 55 bar.	High permanent pressure resistance Small footprint and low weight Cost-effective Robust design Cascade applications Rolling stock and marine applications



Tailor-made for the most varied applications

Kelvion's brazed heat exchangers offer tailor-made solutions for the greatest possible range of applications. Thanks to the automated manufacture and compact design of our EcoBraze Series, we can assemble a customised heat exchanger in the shortest time possible. We choose between copper- and nickel-brazed or VacInox plate heat exchangers depending on the field of application. We look for the most economical solution from the various sizes and diverse accessories available to us and adapt them precisely to your requirements with customised connections.

	Description	Specifications
<p>The GKS Series ConBraze – copper brazed New benchmarks in heat transmission</p>	<p>The GKS Series – highest transfer performance by means of a completely new plate geometry using the improved heat transfer of concave/convex vortex cells.</p>	<p>Increased efficiency – greater output</p> <p>Appreciably less refrigerant</p> <p>Plate corrugations adapted to the application</p> <p>Best suited to heating and refrigeration applications</p>
<p>The GKH Series ConBraze – copper brazed, highest pressures – highest output</p>	<p>Operating pressures up to 50 bar and new plate geometry create an apparatus that satisfies the highest requirements</p>	<p>Greatest pressure resistance</p> <p>Evaporators, condensers and economisers for high-pressure heat pumps and refrigeration systems</p>
<p>The GML Series Copper brazed Conceptualised for the safe use of high-pressure refrigerants</p>	<p>This series is suitable for refrigeration and air-conditioning applications, in which pressures of up to 75 bar must be maintained.</p>	<p>Has a very high pressure resistance</p> <p>Compact and space-saving</p> <p>CO² stands out as a carbon-neutral refrigerant</p> <p>This forward-looking system is an economical and advantageous solution</p>
<p>The DW Series Copper brazed Double-walled safety plate heat exchanger</p>	<p>DW stands for “Double Wall” and assures the greatest safety due to its double-walled, hermetically-sealed heat exchanger plates at pressures up to 45 bar</p>	<p>Double-walled safety construction</p> <p>Reliable separation of the media</p> <p>New plate design</p> <p>More pressure resistant and efficient</p> <p>Conceptualised for heat pumps and domestic connection stations</p>

EcoBraz

COMPACT, COST-EFFECTIVE – FOR SYSTEM PRESSURES UP TO 140 BAR



	Description	Specifications
The GBH-HP Series Copper brazed Highest-pressure heat exchanger with pressure frame	A brazed plate heat exchanger with pressure frame for transcritical and subcritical CO ² applications and industrial fields of application with system pressures up to 140 bar.	Cost-effective and durable with the greatest resistance to pressure Industrial heating and cooling CO ² heat pumps and supermarket refrigeration plants Power station technology
The GNH-HP Series Nickel-based solder For the highest operating pressures	Nickel-based brazed plate heat exchanger for industrial applications with an operating pressure of up to 46 bar combining the advantages of brazed and gasketed heat exchangers.	High thermal efficiency High operating pressure Connection geometry of DN15 up to DN100 Compact design and minimal space requirements Ammonia refrigeration plants and cascades
The TD Series Copper brazed 3-media heat exchanger	True-Dual dual-circuit evaporator represents constant high efficiency. A brazed heat exchanger combining two refrigerating circuits with a water or solar circuit.	Diagonal flow principle for optimal utilisation of the transfer surface TD ensures that this optimum is achieved even when operating at partial load Interlaced channel configuration Both refrigerating circuits in 100% contact with the water/solar circuit Designed for refrigeration plants and heat pump systems



Vaclnox
 a specially-developed plate heat exchanger that is free of non-ferrous metals and suitable for pressures up to 35 bar.

	Description	Specifications
The GVH Series Non-ferrous metal free stainless steel plate heat exchangers Vaclnox – new technology	Our new, unique and revolutionary technology for bonding stainless steel plates enables both a compact design and the greatest corrosion resistance. Vaclnox stainless steel plate heat exchangers are thus the answer for the most stringent requirements in potable water supply and in critical industrial applications up to 35 bar.	Can also be used under extreme conditions and with highly corrosive media Combines the advantages of brazed heat exchangers and great resistance to corrosion and pressure Evaporators and condensers for ammonia systems Laser cooling Potable water heating
The GNS Series Nickel-based solder Highly corrosion-resistant	Copper-free brazed plate heat exchangers offer all advantages of a brazed plate heat exchanger, yet thanks to the special solder are significantly more resistant to corrosive media.	Compact and cost-effective For use with desalinated water and corrosive fluids. Laser cooling Economizer Ammonia systems
The XCR Series Nickel or copper brazed Suitable for pool technology applications	The XCR Series uses stainless steel plates of 1.4547 (SMO 254) and are resistant to chloride content, as is usually found in pool technology.	Long service life due to high-quality stainless steel Corrosion-proof in the face of high chloride content. Upon request, individual testing of the chloride/temperature relationship can be performed

Bloc



Flex

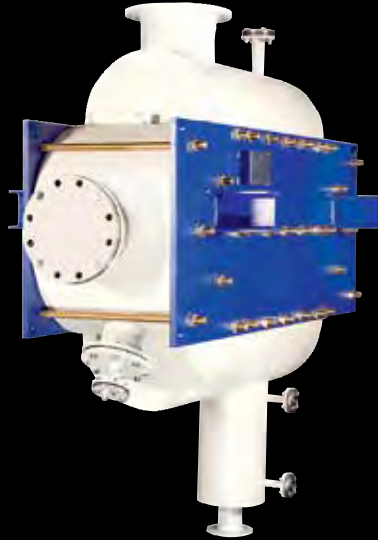

REKULUVO



Our fully-welded plate heat exchangers make a convincing case due to their minimal size, outstanding thermal transmission coefficients and comparatively minimal investment costs. They are particularly robust and require only minimal cleaning and servicing. The design advantages thus come into play in areas in which in addition to the output, load capacity is also required. In addition, each series has its specific advantages and areas of application. The conclusion: Developed for the challenges of specific applications, the EcoWeld product line offers convincing performance even under the most difficult circumstances.

Fully welded plate heat exchangers

FOCUSED ON THE MOST STRINGENT REQUIREMENTS

Overview of the fully welded plate heat exchangers

	Bloc	Flex	REKULUVO/ REKUGAVO
Maximum temperature	350 °C	900 °C	700 °C
Maximum pressure	35 bar	60 bar	1,4 bar (max. 0,4 Diff.)
Area	1-860 m ²	1-12.000 m ²	500-250.000 m ²
Maximum volume flow	10.000 m ³ /h	15.000 m ³ /h	variable

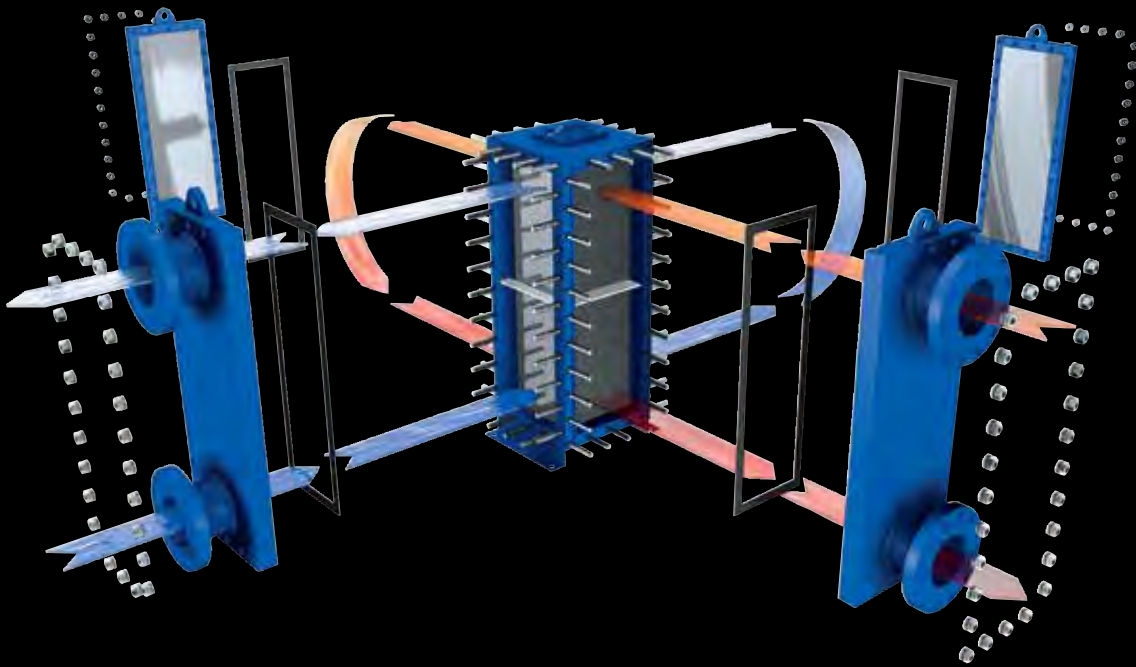

Two different plate corrugations

The compact, fully-welded heat exchanger can be equipped with two different plate corrugations, as required by their application. The chevron corrugation assures highly efficient heat transfer, the double-dimple corrugation is most suited to demanding media with high viscosity or for vacuum condensation.

Bloc

FULLY WELDED FOR OIL AND GAS AS WELL AS PETROCHEMICALS

Kelvion's Bloc is a fully-welded plate heat exchanger that is used above all in the oil and gas industry, the chemical industry as well as in the petrochemical sector. The solidly bolted frame consists of four columns, top and bottom plates as well as four side plates. These can be detached swiftly and allow

free access all the way around for the thorough and easy cleaning of the fully-welded plate packages. Two different plate corrugations are available. Chevron corrugation enables effective heat transfer. In contrast, dimple corrugation is the first choice for highly viscous media.

Their advantages at a glance

- Fully welded plate heat exchanger package
- for applications at temperatures up to 350 °C and pressures up to 35 bar
- small footprint and low installation cost
- Access to both sides of the media
- easy cleaning thanks to unproblematic opening of the apparatus

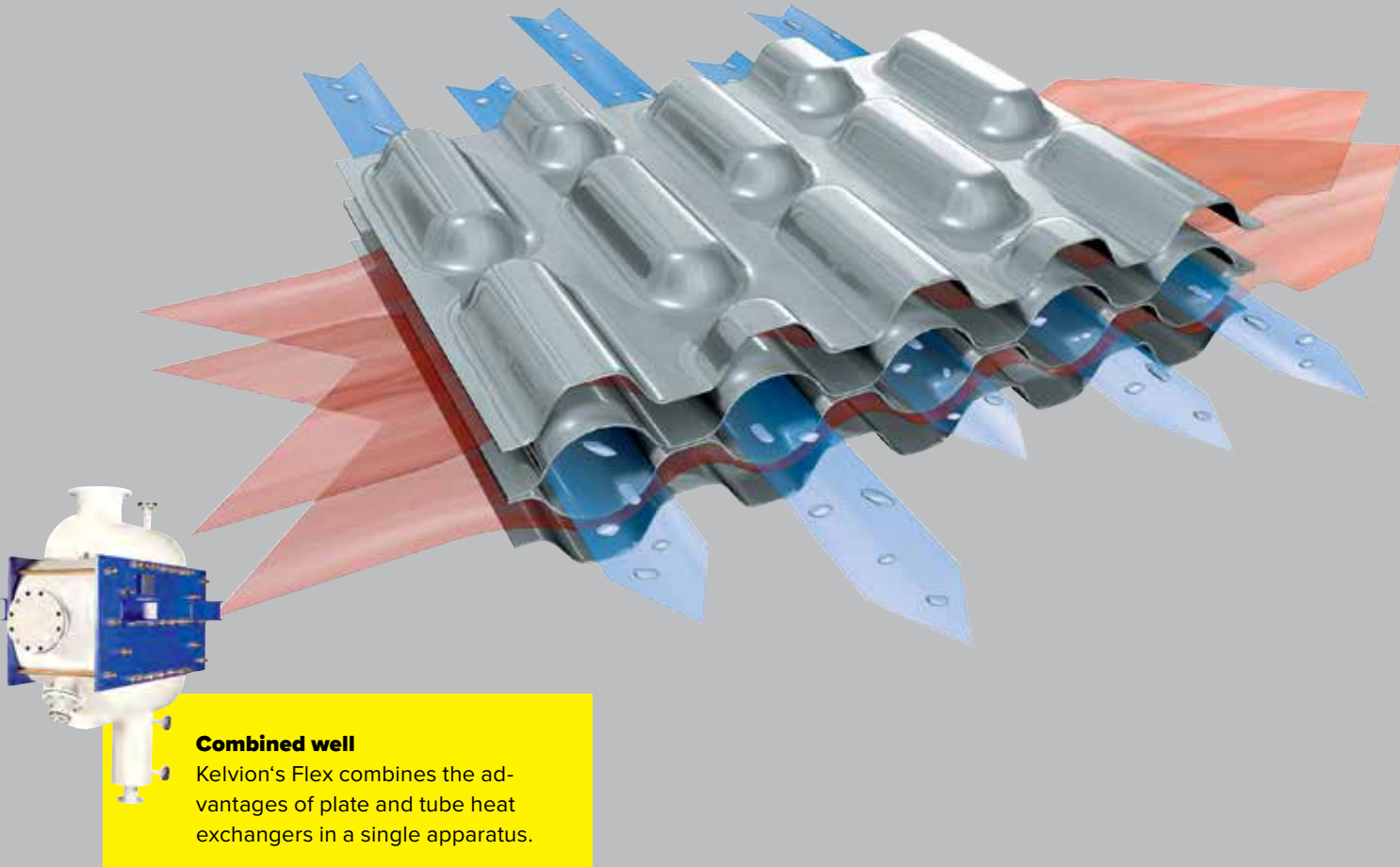

Combined well

Kelvion's Flex combines the advantages of plate and tube heat exchangers in a single apparatus.

Flex

**FULLY WELDED
FOR MULTIPLE
APPLICATIONS**

Kelvion's Flex combines the advantages of shell-and-tube and plate heat exchangers in a single apparatus. This makes it predestined for the most varied applications: e.g. as a condenser in the power station sector, as a plate-type falling-film evaporator in the sugar industry, as a condenser, evaporator and heat exchanger for the thermal treatment of 2-phase mixtures in the chemical and petrochemical industries as well as in the oil and gas industry.

Thanks to its customisable design it is equally successful when used as a head condenser. The plate structure enables a high output density. Efficient, turbulent heat transfer is already possible at minimal temperature differentials and varying volume flows. Even in the case of a large volume flow, the loss of pressure at the tube is minimal. In comparison with previous solutions, the effort involved in cleaning is clearly reduced.

Their advantages at a glance

- media containing fibres and solids can be used at the tube-side with a large, open flow area
- high condensation outputs up to 200 MW and condensate supercooling in a single apparatus
- operation in a vacuum with minimal pressure losses
- variable temperature limits up to 900 °C
- variable pressure limits up to 60 bar as well as high pressure differentials between media

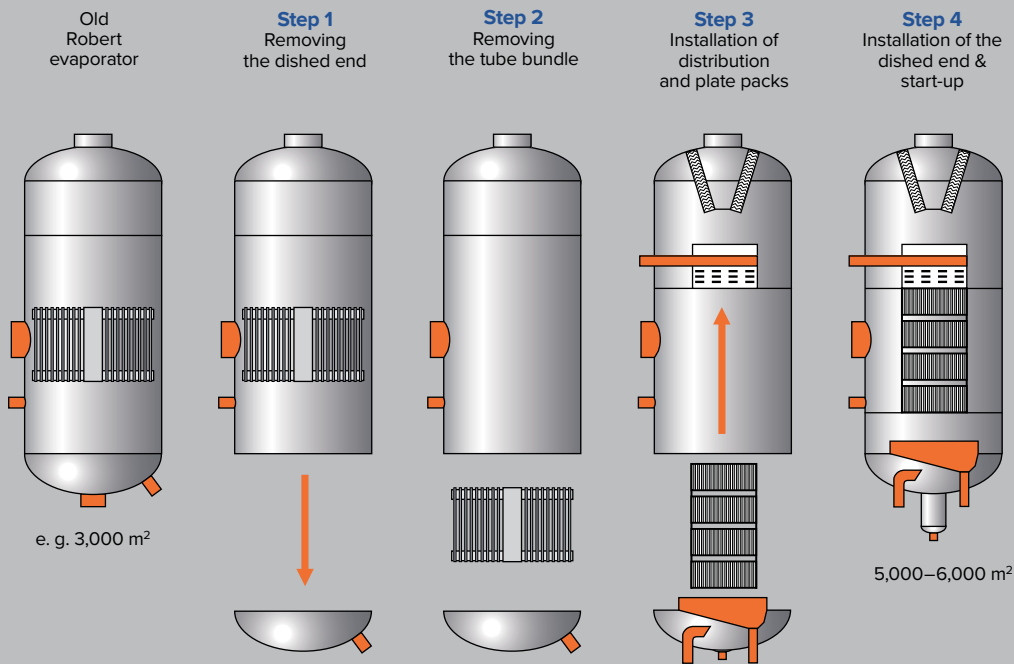

A gentle high-performance evaporator

Outstanding thermodynamic characteristics enable energy-saving designs. The design aimed at efficiency simultaneously assures gentle handling of the sugar syrup by means of low temperature differentials and short dwell times.

EvapPlus

AS EVAPORATOR IN THE SUGAR- INDUSTRY

As gentle product handling and energy saving are at the forefront in sugar production, the EVAPplus plate-type falling film evaporator is precisely the right solution. The most modern technology ensures the highly efficient concentration of sugar beet and sugar cane syrup. The advantages of the EVAPplus can also be applied to the subsequent output increase of existing Robert

evaporators. Alterations to buildings, foundations or to the statics of the plant are usually not required in doing so. The heating coil is simply removed from the Robert evaporator and replaced with a EVAPplus plate package with a manifold. The heating surface and the efficiency of the system is thus considerably improved with minimal cost.

Their advantages at a glance

- highest heat transfer rates
- minimal temperature differentials
- short dwell time of the syrup in the apparatus
- high heating surface density
- minimal syrup discolouration

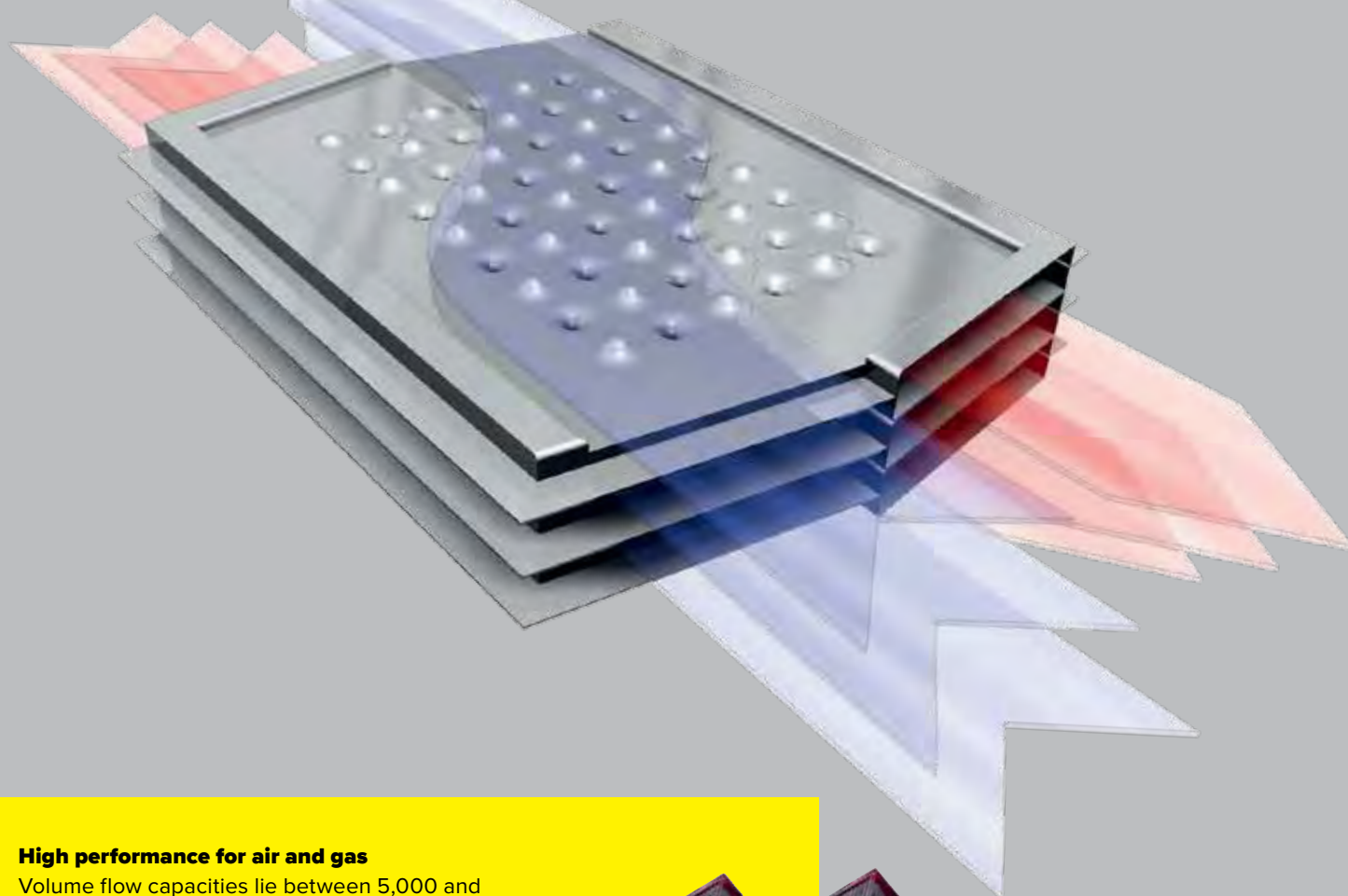

High performance for air and gas

Volume flow capacities lie between 5,000 and 2,000,000 Nm³/hr. In these quantities, air and flue gas are raised to a temperature of 700 °C without any trouble. In doing so, a recovery rate of up to 97 % is achieved.

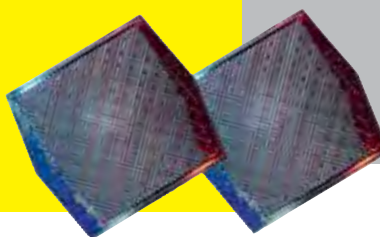

REKULUVO®/REKUGAVO®

FULLY WELDED – HIGH PERFORMANCE FOR AIR AND GAS

Our REKULUVO/REKUGAVO exhaust gas heat exchangers have been specially developed for applications with gaseous media containing pollutants. They are used in thermal power stations, ammonia and methanol factories as well as in environmental technology. Wherever especially high-performance exhaust air or exhaust gas heat

exchangers are required, our REKULUVO/REKUGAVO can be used; for example to preheat sucked-in combustion air or to heat flue gases to the reaction temperature of a catalyst. By means of the counterflow principle, the REKULUVO/REKUGAVO achieves an exceptionally high efficiency of up to 97 %.

Their advantages at a glance

- media containing fibres and solids can be used at the tube side with a large, open flow area
- high condensation outputs up to 200 MW and condensate supercooling in a single apparatus
- operation in a vacuum with minimal pressure losses
- variable temperature limits up to 900 °C
- variable pressure limits up to 60 bar as well as high pressure differentials between media

GASKETED PLATE HEAT EXCHANGERS

Model	Connection size	Dimensions	
	(in mm)	Height (in mm)	Width (in mm)
NT Series 250M ... 150L			
NT 25M	25	570	180
NT 50T	50	670	323
NT 50M	50	930	323
NT 50X	50	1,390	323
NT 80M	80	1,271	435
NT 100T	100	1,110	540
NT 100M	100	1,516	540
NT 100X	100	1,952	540
NT 150S	150	1,717	640
NT 150L	150	2,197	640
NT Series 250S ... 500X			
NT 250S	250	2,272	895
NT 250M	250	2,569	895
NT 250L	250	2,866	895
NT 350T	350	2,553	1,135
NT 350S	350	2,776	1,135
NT 350M	350	3,113	1,135
NT 350L	350	3,450	1,135
NT 500T	500	3,257	1,415
NT 500M	500	3,868	1,415
NT 500X	500	4,479	1,415
NX Series 100X ... 250L			
NT 25M	25	570	180
NX 100X	100	1,952	540
NX 150X	150	2,377	640
NX 250L	250	2,866	895
NH Serie			
NH 250S	250	2,272	895
NH 250M	250	2,569	895
NH 250L	250	2,866	895
NH 350S	350	2,776	1,135
NH 350M	350	3,113	1,135
NH 350L	350	3,450	1,135
ND Safetytherm			
ND 50M	50	930	323
ND 50X	50	1,390	323
ND 100T	100	1,110	540
ND 100M	100	1,516	540
ND 100X	100	1,952	540
ND 150S	150	1,717	640
ND 150L	150	2,197	640

GASKETED PLATE HEAT EXCHANGERS

Model	Connections	Dimensions	
	(in mm)	Height (in mm)	Width (in mm)
LWC Series 100T ... 350S			
LWC 100T	100	1,110	540
LWC 100M	100	1,516	540
LWC 100X	100	1,952	540
LWC 150S	150	1,717	640
LWC 150L	150	2,197	640
LWC 250S	250	2,272	895
LWC 250L	250	2,866	895
LWC 350S	350	2,776	1,135
Free Flow			
N 40	100-125	1,570	710
FA 184	200	2,015	910
FA 192	350	2,765	1,370
NF 350	350	3,450	1,380
Concitherm			
CT 187	max. 350	2,870	1,000
CT 193	max. 600	2,698	1,650
GG Series			
GG 240H	25	464	100
GG 500H	32	535	140

*) discontinued ; **) discontinued as from 2013

BRAZED PLATE HEAT EXCHANGERS

Model	Operating pressure up to		Dimensions	
	(in bar)		Height (in mm)	Width (in mm)
GBS Series				
GBS100	31		204	74
GBS200	31		231	90
GBS220	31		328	90
GBS240	31		464	91
GBS300	31		173	124
GBS400/GBS400-AE	31		335	124
GBS418	40		282	127
GBS420	31		282	127
GBS500/GBS500-AE	31		532	124
GBS525	36		525	118
GBS700/GBS700-AE	31		532	271
GBS757	35		543	281
GBS760	27		519	257
GBS800/GBS800-AE	31		532	271
GBS900/GBS900-AE	31		802	271
GBS910	36		783	318
GBS1000/GBS1000-AE/BE	31		875	386
GBH Serie				
GBH100	45		204	74
GBH200	45		231	90
GBH220	45		328	90
GBH240	45		464	91
GBH300	45		173	124
GBH400/GBH400-AE	45		335	124
GBH500/GBH500-AE	45		532	124
GBH700/GBH700-AE	45		532	271
GBH800/GBH800-AE	45		532	271
GBH900/GBH900-AE	45		802	271
GBH1000/GBH1000-AE/BE	45		875	386
GBE/GKE Series				
GBE100	16		204	74
GBE200	16		231	90
GBE220	16		328	90
GBE240	16		464	91
GBE400	16		335	124
GBE500/GKE500	25		532	124

BRAZED PLATE HEAT EXCHANGERS

Model	Operating pressure up to	Dimensions	
	(in bar)	Height (in mm)	Width (in mm)
GWH Series			
GWH220	55	328	90
GWH240	55	464	91
GWH500/GWH500-AE	55	532	124
GWH700/GWH700-AE	55	532	271
GWH900/GWH900-AE	55	802	271
GKS Series			
GKS550/GKS550-AE	40	532	124
GKS770/GKS770-AE	30	539	278
GKH Series			
GKH550/GKH550-AE	50	532	124
GKH770/GKH770-AE	45	539	278
GNS Series			
GNS100	16	204	74
GNS200	16	231	90
GNS220	16	328	90
GNS240	16	464	90
GNS300	16	173	124
GNS400/GNS400-AE	16	335	124
GNS500/GNS500-AE	16	532	124
GNS700/GNS700-AE	16	532	271
GNS800/GNS800-AE	16	532	271
GVH Series			
GVH100	35	204	74
GVH200	25	231	90
GVH220	25	328	90
GVH240	25	464	90
GVH300	25	173	124
GVH400/GVH400-AE	25	335	124
GVH500/GVH500-AE	25	532	124
GVH700/GVH700-AE	27	532	271
XCR Series			
GBS/GNS220-XCR	31 (GBS) / 16 (GNS)	328	90
GBS/GNS240-XCR	31 (GBS) / 16 (GNS)	464	91 (GBS) / 90 (GNS)
GBS/GNS400-XCR	31 (GBS) / 16 (GNS))	335	124
WP5/GNS500-XCR	31 (WP) / 16 (GNS)	532	124
WP7/GNS700-XCR	31 (WP) / 11 (GNS)	532	271
DW Series			
GBS/GBH400-DW	16 (GBS) / 45 (GBH)	335	124
GBS/GBH500-DW	16 (GBS) / 45 (GBH)	532	124
TD Series			
TD7/TD7-AE	30	532	271
TD9/TD9-AE	25	802	271

BRAZED PLATE HEAT EXCHANGERS

Model	Operating pressure up to	Dimensions	
	(in bar)	Height (in mm)	Width (in mm)
GML Series			
GML400	70	335	124
GML500	70	532	124
Series BPHE with pressure frame			
GNS-HP500/ GNS-HP500-AE	27	600	195
GNS-HP700/ GNS-HP700-AE	27	650	340
GNH-HP500/ GNH-HP500-AE	46	600	195
GNH-HP700/ GNH-HP700-AE	46	621	340
GBH-HP500/GBH-HP500-AE	140	600	195
GBH-HP700/GBH-HP700-AE	140	621	340
GBH-HP1000/GBH-HP1000-AE	130	1,050	500
GBH-HP-DW500	140	600	195
GGE/GGS Series			
GGE/GGS240	11 (GGE) / 16 (GGS)	465	100
GGE/GGS500	11 (GGE) / 16 (GGS)	535	140
GGE/GGS-DG Series			
GGE/GGS-DG240	10 (GGE) / 16 (GGS)	482.5	110.3
GGE/GGS-DG500	10 (GGE) / 16 (GGS)	560	152

FULLY WELDED PLATE HEAT EXCHANGERS

Model	Connection size	Dimensions	
	(in mm)	Height (in mm)	Length = Width (in mm)
Bloc			
BT20	max. 150	798	318
BT30	max. 250	1,439	397
BT40	max. 300	1,764	507
BT50	max. 350	2,116	615
BT75	max. 600	3,319	914
BT120	max. 900	3,681	1,500

Flex

Indications of size cannot be given at this point, as the process requirements as well as the outputs influence the dimensions of the plate heat exchangers. Please contact us

REKULUVO®/REKUGAVO®

Indications of size cannot be given at this point, as the process requirements as well as the outputs influence the dimensions of the plate heat exchangers. Please contact us



Our service is at your doorstep.

First and foremost, service makes a good product and a satisfied customer. At Kelvion, we make use of a close-knit service network with trained technicians – worldwide! You receive everything from a single source – inspection, repair, exchange, etc. – promptly, punctually and technically sound, including products or subcomponents from other suppliers. Only high-quality original parts are used. This guarantees secure seating, efficient operation and a long service life.

AFTER-SALES & SERVICE

AVAILABLE WORLDWIDE AND 24 HOURS A DAY

Kelvion is the leading service specialist for plate heat exchangers of all types and manufacturers / brands. The spectrum includes all after-sales and service from assembly through maintenance and spare part supply to preventative measures such as the innovative gasket test. The global network of locations enables service 24/7. In so doing, we support you everywhere and at all times to obtain the maximum availability of your systems.

This includes the assembly of the apparatus. The fully-assembled approach has a decisive effect on problem-free functioning. Kelvion is also available to assemble the plate heat exchangers in the event that the system is delivered in a disassembled state. Preventative maintenance is a further service. Plate heat exchangers can become dirty or worn. We offer a visual check

as preventative maintenance and inform you regarding the cleaning or servicing required and the expected costs. Minor contamination can also be removed immediately on site. The safe alternative is, however, mechanical or chemical treatment of the plates in Kelvion's special workshops.

Our main aim is to ensure the long-term availability of the apparatus. High-quality and absolutely tailored spare parts are essential for the trouble-free operation of your plate heat exchanger. In addition to original parts, we also offer certified products of other quality suppliers, whose attractive price-to-performance ratio is particularly valued by our clients. Plates and gaskets for practically all brands and types are kept in stock continuously, or are supplied at short notice.

The five basic reasons that make us leading specialists:

- **Quality and safety:** Highest quality service is the result of individual customer service and precise work.
- **Innovation:** Flexibility creates solutions for the various specifications of our clients.
- **Efficiency:** Optimised operational processes and maximal availability of systems assures greater efficiency.
- **Expertise:** Diverse knowledge and experience lead to pooled competencies – thus offering our customers decisive advantages.
- **Trustworthiness:** Reliability, a sense of responsibility and transparency when communicating with the client distinguish the manner in which our service personnel work..



Kelvion quality for all your projects – worldwide

The latest production and service facilities ensure that Kelvion's enterprises reach a high level of productivity. Quantity is never-the-less not without quality. We manufacture high-precision plate heat exchangers, which have proved themselves thousands of times, especially due to their outstanding quality features. And that almost on your doorstep.

At home around the world

TAILOR-MADE PLATE HEAT EXCHANGER SOLUTIONS

Belgium

Kelvion BVBA
Warandestraat 1
9240 Zele, Belgium
Phone: +32 52 456 600
Fax: +32 52 456 609
Email: zele@kelvion.com

China

Kelvion PHE Ltd
No.218 Lane 1409
Ji Di Road, Min Hang District,
Shanghai 201107, China
Phone: +86 21 629 60872
Fax: +86 21 629 61973
Email: info.phe.china@kelvion.com

Danmark

Kelvion AB
Helge Nielsens Alle 6D
8723 Løsning, Danmark
Phone: +45 51 27 14 55
Fax: +46 411 55 55 61
Email: scandinavia@kelvion.com

Germany

Kelvion PHE GmbH
Karl-Schiller-Str. 1-3
31557 Sarstedt, Germany
Phone: +49 5066 601 0
Fax: +49 5066 601 104
Email: sarstedt@kelvion.com

Kelvion Brazed PHE GmbH
Remsaer Straße 2a
04603 Nobitz-Wilchwitz,
Germany
Phone: +49 3447 5539 0
Fax: +49 3447 5539 30
Email: sales.nobitz@kelvion.com

France

Kelvion PHE France
6 avenue du Vieil Etang
78180 Montigny le Bretonneux,
France
Phone: +33 130 142 880
Fax: +33 130 142 888
Email: infofrance@kelvion.com

Finland

Kelvion AB
Hirsalavägen 11
02420 Hirsala, Finland
Phone: +358 40 826 7959
Fax: +46 411 55 55 61
Email: scandinavia@kelvion.com

Great Britain

Kelvion Ltd. / PHE
3 Maybrook Road
Birmingham B76 1AL,
Great Britain
Phone: +44 121 352 3340
Fax: +44 121 352 3343
Email: birmingham@kelvion.com

India

Kelvion India Pvt. Ltd
A-31/32, Chakan MIDC Phase-IV,
Village Nighoje, Tal-Khed,
Pune 410 501, India
Phone: +91 2135 619 500
Fax: +91 2135 619 566
Email: info.phe.india@kelvion.com

Italy

Kelvion S.r.l.
via A.M. Da Erba Edoari 29/A
43123 Parma, Italy
Phone: +39 0521 247 311
Fax: +39 0521 247 333
Email: parma@kelvion.com

Japan

Kelvion K.K.
Uchisaiwaicho Kikaku Bldg.
1-15-6 Nishishinbashi
Minato-Ku, Japan
Tokyo 105-0003, Japan
Phone: +81 3620 26537

Korea

Kelvion KOS Korea Ltd.
40-147, 4th Floor, Hangangro-3ka,
Yongsan-ku, Seoul, Korea
Phone: +82 2 3781 0502
Fax: +82 2 3781 0505

Malaysia

Kelvion Sdn. Bhd.
S-12B-02, First Subang,
Level 12B, Jalan SS15/4G, 47500
Subang Jaya, Selangor Darul
Ehsan, Malaysia
Phone: +603 5631 0848
Fax: +603 5631 0841
Email: malaysia@kelvion.com

Middle East (UAE)

Kelvion FZE
Jebel Ali Free Zone
South 2 AC-03, Dubai
Phone: +971 488 62100
Fax: +971 488 62101
Email: infome@kelvion.com

Netherlands

Kelvion PHE B.V.
Craenakker 21
5951CC Belfeld, Netherlands
Phone: +31 77 475 99 00
Fax: +31 77 475 99 09
Email: belfeld@kelvion.com

Norway

Kelvion AB
Trångsundsvägen 20
393 65 Kalmar, Sweden
Phone: +46 10 209 19 00
Fax: +46 411 55 55 61
Email: scandinavia@kelvion.com

Poland

Kelvion Sp. z o.o.
Al. Jerozolimskie 146d
02-305 Warszawa, Poland
Phone: +48 22 608 14 37
Fax: +48 22 608 14 25
Email: warsaw@kelvion.com

Russia

Kelvion Mashimpeks LLC
Malaya Pochtovaya, 12 b.1
Moscow, 105082, Russia
Phone: +7 495 234 95 03
Fax: +7 495 234 95 04
Email: moscow@kelvion.com

Saudi Arabia

Kelvion FZE
Tareeq 114, Al Jubail,
Saudi Arabia
Phone: +966 553 213 187
Fax: +971 488 62101
Email: infome@kelvion.com

South Africa

Kelvion Services (Pty) Ltd
Aberdein Street
Roodekop
Germiston 1401, South Africa
Phone: +27 11 866 4000
Fax: +27 11 866 4040
Email: service.germiston@kelvion.com

South-East Asia

Kelvion Pte. Ltd.
40 Gul Crescent
Singapore 629540
Phone: +65 666 404 30
Fax: +65 686 255 03
Email: singapore@kelvion.com

Spain

Kelvion Thermal Solutions, S.A.U.
San Juan, 28
48140 Igorre, Spain
Phone: +34 94 631 9467
Fax: +34 94 631 5145
Email: igorre@kelvion.com

Sweden

Kelvion AB
Trångsundsvägen 20
393 65 Kalmar, Sweden
Phone: +46 10 209 19 00
Fax: +46 411 55 55 61
Email: scandinavia@kelvion.com

USA

Kelvion Inc.
100 GEA Drive, York
PA 17406, USA
Phone: +1 717 268 6332
(Service Direct Dial)
+1 717 268 6200 (Main)
Email: york@kelvion.com

www.kelvion.com